

AccuGuide™

Positive Displacement Guides

PDG-PS Series



Choose from 5 standard
AccuGuide PDG-PS models.

PDG-PS Series
web guide assemblies are
a cost effective solution
for narrow web applications

The AccuGuide PDG-PS Series, part of AccuWeb's complete line of Positive Displacement Guide systems, are engineered for ease of use and dependability. These compact, formed steel guides are cost effective systems that deliver reliable performance. Three or more proprietary linear bearings support and secure the moving frame and idler roller assembly to its stationary base. This unique linear bearing system allows the guide assembly to be installed in a vertical, horizontal or inverted position for optimum application performance.

Like Every AccuWeb® Guide Component, the AccuGuide PDG-PS Series is Built to Last.

- **Proprietary Linear Bearing System** — Cam follower bearings run in a hardened track to reduce friction and wear, allowing for a faster, more accurate response.
- **Simple, Drop-in Installation** — Optional cantilevered brackets and guide mounted or remote mounted switch pads provide fast, trouble-free installation.
- **Free-turning Idler Rollers** — Free-running bearings minimize rotational torques — ideal for running light webs. Dynamically balanced rolls ensure vibration-free performance.
- **Projected Pivot Point** — The unique bearing system is designed to position the pivot point exactly on the incoming web plane to ensure guide accuracy.

Optional
cantilevered
brackets ease
installation

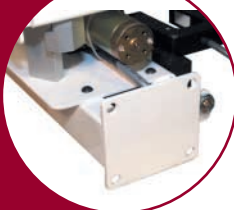

Optional
edge detector
mounting brackets
are designed for
fast, accurate
micro adjustments



Optional guide
mounted touch pad
simplifies operation.



Specific models
designed for
retrofits



Manufactured in the United States
under one or more patents and trademarks.



AccuWeb, Inc.
www.accuweb.com

A Modular Design For Drop-in Installation

PDG-PS-060802



A PDG is the most common and accurate way to guide a web. It requires relatively small entry and exit spans. The moving frame pivots on the incoming web plane to guide the web to its desired position. The AccuGuide PDG-PS Series are engineered for web widths ranging from 2" (51 mm) to 16" (406 mm).

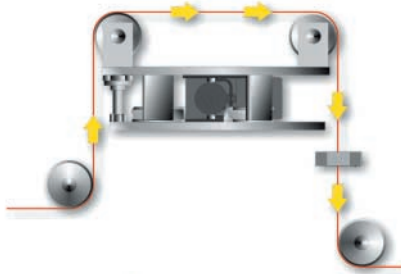

Typical web threading configurations

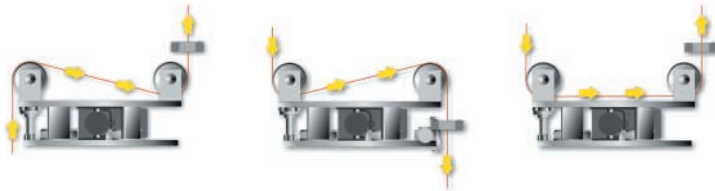

Mounting Options

- Left-right or Right-left
- Rollers upright or inverted
- Cantilevered mounting brackets
- Touch pad mounting on a cantilevered bracket

Roller Options

- Plasma Coated
- Rubber Covered
- Hard-coat Anodized
- Cork Covered
- Micro-grooved
- Teflon®

Standard AccuGuide PDG-PS Series Sizes

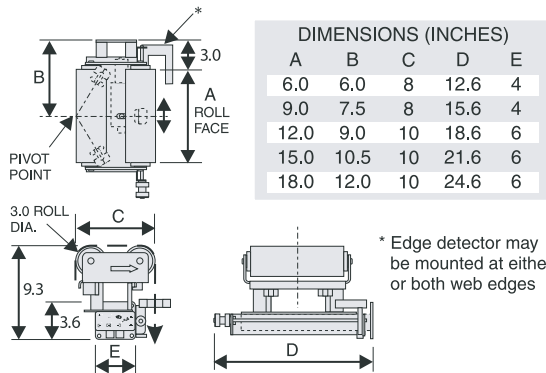

The AccuGuide Series of PDGs Include:

- PDG-FS Series – a heavy-duty guide with tubular steel framing
- PDG-AP Series – a premium mid to narrow web guide with anodized aluminum plate construction
- PDG-PS Series – an economical narrow web guide featuring a modular, drop-in design

Model Nomenclature

Example: Model 121002 PDG-PS

12 10 02

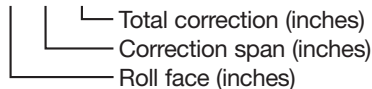

Toll free: (888) 422-2893 • Web site: www.accuweb.com

An AccuWeb® System is a Sound Investment

- **Tangible Benefits —**
While web guides represent a nominal expense within an entire converting line, they can have considerable impact on product quality, process waste, operating speeds, efficiency and maintenance costs. Choosing a web guide system that delivers optimum trouble-free performance is a wise investment.
- **The Support of Web Guide Experts —** The AccuWeb application engineering team helps you determine the best guide design and location to fit your specific converting operation. By evaluating your web widths, materials and change-over frequencies, as well as operating environment, AccuWeb helps ensure greater harmony between our innovative guide components and your web converting process for an optimum return on your investment.

World Headquarters

P.O. Box 7816
Madison, WI U.S.A. 53707

Phone: (608) 223-0625

Fax: (608) 223-0074

European Sales and Support

Formanguieres 87
CH-1782 Belfaux/Switzerland

Phone: +41 26 475 5028

Fax: +41 26 475 5025